

Specifications

Operating Specifications

Rated load capacity

TH60	6,000 lbs. (2722 kg)
TH80	8,000 lbs. (3629 kg)

Maximum lift height 41.5 ft. (12.6 m)

Load at max. height, no stabilizers

TH60	6,000 lbs. (2722 kg)
TH80	8,000 lbs. (3629 kg)

Load at max. height, stabilizers down

TH60	6,000 lbs. (2722 kg)
TH80	8,000 lbs. (3629 kg)

Maximum forward reach 27 ft. 2 in. (8.3 m)

Load at max. reach, no stabilizers

TH60	1,000 lbs. (454 kg)
TH80	1,825 lbs. (828 kg)

Load at max. reach, stabilizers down

TH60	3,000 lbs. (1361 kg)
TH80	4,000 lbs. (1814 kg)

Top travel speed 21.1 mph (34 kph)

Max. reach below grade 48 in. (1.2 m)

Outside turning radius	12 ft. 10 in. (3.9 m)
Ground clearance	16.25 in. (41.3 cm)
Overall height	95.8 in. (2.4 m)
Overall width	95.7 in. (2.4 m)
Overall length	230.7 in. (5.8 m)
Weight	
TH60	19,180 lbs. (8700 kg)
TH80	21,385 lbs. (9700 kg)
Lift height	41.5 ft. (12.6 m)
Hydraulic oil capacity	40 gal. (151 L)
Fuel tank capacity	32 gal. (121 L)
Standard tires	13:00 x 24 16PR
Frame tilt to left or right	10°/10°

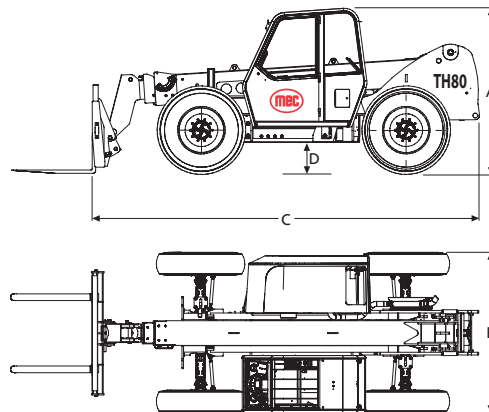

Dimensions

A) Height	95.8 in. (2.4 m)
B) Width	95.7 in. (2.4 m)
C) Length to Fork Face	230.7 in. (5.8 m)
D) Ground Clearance	16.25 in (41.3 cm)

Standard Equipment

Engine

Deutz D4D 2012 BF4M

Cab

Heating, defrosting, de-icing system with four adjustable ducts. Multi-position suspension seat. Dome light. Armrest mounted joystick. Lockable storage under seat. Storage area behind seat. Load charts. ROPS/FOPS certified. Rubber floor mat. Single key for all locks. Laminated front, top windows. Left and right rear view mirrors.

Axle

Final reduction in wheel hubs by a four pinion outboard planetary drive.

Transmission

Powershift transmission with 4 speeds forward, 3 speeds reverse.

Brakes

Multi-plate, oil immersed, power assisted, self adjusting internal disc brakes with four wheel braking. Six discs per axle. Internal front axle parking brake engages when engine is shut off. Fully powered brake valve with accumulator back-up.

Electrical system

95 amp alternator and 12 volt, 900 CCA battery. Sealed switches.

Instrumentation and Controls

Fuel gauge, hour meter, tachometer.

Hydraulic System

Dual axis joystick. 32 gpm system capacity. Closed center, flow-sharing, load sensing, control valve.

Safety

Horn and backup alarm. Lockable hydraulic access door.

Optional Equipment

Operator's Area

Cab enclosure with heater and defroster. Tilt steering with foot adjustment. Windshield wiper and washer.

Electrical

Roadway light package. Work light packages. Complete road lights.

Engine

Cold start package.

Hydraulics

Auxiliary hydraulic circuit.

Attachments

Carriage – 48" (122 cm)
Carriage – 60" (152 cm)
Carriage – 72" (183 cm)
48" Tilt Carriage (122 cm)
60" Tilt Carriage (152 cm)
72" Tilt Carriage (183 cm)
52" Side Shift Carriage (132 cm)
54" Swing Carriage (137 cm)
72" Swing Carriage (183 cm)
Pallet Fork 2 x 4 x 48 (set of two)

Pallet Fork 2 x 4 x 60 (set of two)
Pallet Fork 2 x 4 x 48 (set of two)
Block Fork 2 x 2 x 48 (set of two)
Lumber Fork 1.75 x 48 (set of two)
Lumber Fork 1.75 x 60 (set of two)
Fork 2 x 5 x 48 (set of two)
Fork 2 x 5 x 60 (set of two)

Other

Front and rear fenders.
Front stabilizers.